



**DANGER**



**READ AND OBEY ALL SAFETY AND OPERATING  
INSTRUCTIONS BEFORE OPERATING TOOL.**



# **RAMSET T3 TOOL SYSTEMS**

## **T3SS SINGLE SHOT & T3 MAGAZINE OPERATOR'S SAFETY & OPERATING INSTRUCTION MANUAL**



**GAS POWERED, LOW VELOCITY  
PISTON TYPE FASTENING TOOL**

**Tri-Lingual**  
English  
Español  
Française

**DANGER**

**THIS TOOL IS TO BE USED ONLY BY PROPERLY TRAINED OPERATORS. ATTEMPTING TO HANDLE OR OPERATE THE T3 GAS POWERED TOOL WITHOUT PROPER TRAINING CAN RESULT IN SERIOUS INJURY TO THE OPERATOR OR BYSTANDERS.**



**! Read, understand and follow the instructions in the tool manual before attempting to use the tool.**



**! Operators and Bystanders must wear eye and hearing protection.**



**! Never close tool with hand over the fastener loading end of the tool. A serious hand injury from penetration by the piston or fastener could result.**



**! The gas in fuel cells is under pressure and the gas is flammable.**

**! Do not open, puncture or burn fuel cells.**



**! Store fuel cells in a well ventilated area, at temperatures below 50° C (122° F) and out of the sunlight.**

**! Keep fuel cells away from flames, sparks and heat.**

**! Do not attempt to recharge, refill or recycle fuel cells.**

**! Never operate the T3 tool if flammable or explosive materials are nearby.**

**DANGER**

Just as no one can merely read a book about driving an automobile and then hope to drive one safely, no one should attempt to use T3 gas powered tools without adequate, competent personal instruction.

No automobile instruction book or instructor can forewarn a learner against all possibilities and emergencies, nor can printed material detail all possible conditions surrounding the use of Ramset tools and products.

**Responsibility for the safe and proper use of this tool rests with the tool user and the employer.**

## Preparation For Fastening

### Acceptable Base Materials

The gas powered T3 tools are suitable for use in the following base materials only:

- Poured Concrete
- Structural Steel
- Concrete Block and Horizontal Joints in Brick or Masonry Walls

**Never attempt to fasten into any other type of material.** *Fastening into other materials can cause blindness or other serious injury.*

**Never attempt to fasten into very hard or brittle materials such as cast iron, tile, glass, or rock of any type.** *These materials can shatter, causing the fastener and/or base material fragments to fly free and cause serious injury to the tool operator and others.*

**Never fasten into any base material that does not pass the Center Punch test.** *Failure to assure the suitability of the base material can result in serious injury to the eyes or other body parts.*

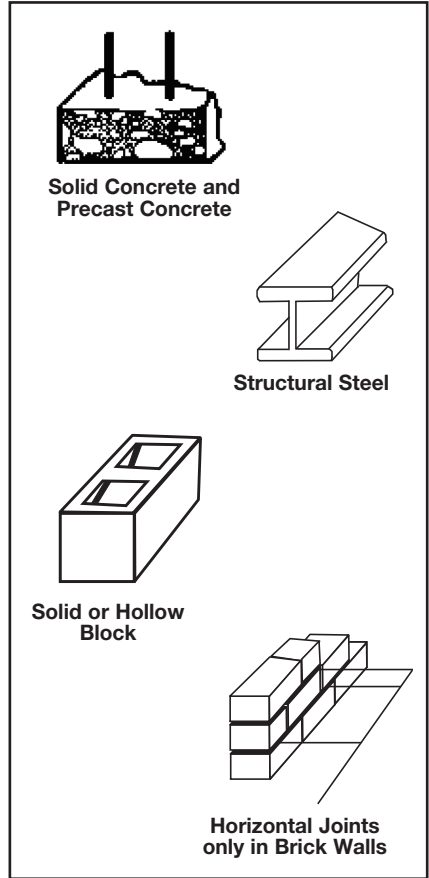

## Center Punch Test

**ALWAYS WEAR SAFETY GOGGLES WHEN PERFORMING THIS TEST.**

1. Always check the material being fastened into for hardness before attempting any fastening operation.
2. Using a fastener as a center punch, strike the fastener against the work surface using an average hammer blow and check the results.

## Center Punch Test Results

1. If the fastener point is flattened, the material is too hard for a powder actuated fastening.
2. If the fastener penetrates the material easily, the material is too soft.
3. If the material cracks or shatters, the material is too brittle.
4. If the fastener makes a small indentation into the material, the material is suitable for fastening.

# FASTENING APPLICATIONS

---

## FASTENING APPLICATIONS

Your T3 tools can be used for a wide range of fastening needs in a variety of base materials. Reading and following these important fastening guidelines will help you get the best results from your tool and fasteners, as well as help you perform these fastening operations safely and effectively.

***T3 fastenings are permanent fastenings so attempting to remove a fastener from concrete or steel may result in a serious injury.***

### Fastening to Concrete

When fastening into concrete, always maintain a minimum spacing of 3" between fastenings and 3" from any free edge. Concrete thickness should be at least three times the intended penetration depth into the concrete.

***Driving fasteners too close to an edge or too close to each other can cause the concrete edge to fail or fasteners to fly free.***

### Fastening to Concrete Block or to Masonry Walls

Take care to observe a 3" edge distance to avoid cracking the block and over penetration of the fastener to avoid a loss of holding value. Fastenings may also be made into the horizontal joint but not into the vertical joint.

### Fastening to Steel

Your T3 tools can be used for fastening on the flat surfaces of structural steel. When fastening into steel, always maintain a minimum spacing of 1-1/2" between fastenings and 1/2" from any edge.

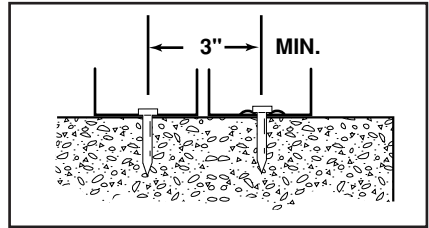

**SPACING - THIN GAUGE METAL TO CONCRETE**

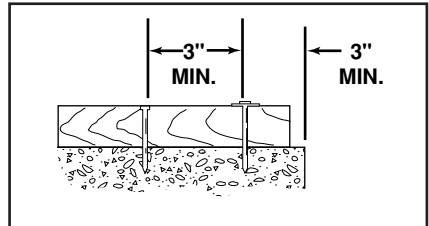

**SPACING - THIN WOOD STRIP TO CONCRETE**

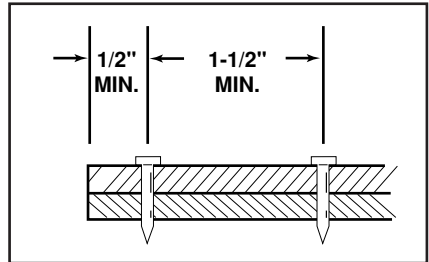

**SPACING STEEL TO STEEL**

**FAILURE TO FOLLOW INSTRUCTIONS CAN CAUSE INJURY TO THE TOOL OPERATOR OR TO BYSTANDERS.**

- Use the tool only in well ventilated areas.
- Always hold the tool at right angles to the work surface.
- Never attempt to make a fastening at an angle to the work surface.
- While the tool can be used in any position (floor, wall or ceiling) it is important to have both the nose of the tool and support foot in contact with the work surface to minimize spall and make the best quality fastenings.
- Do not put a fastener into the nose of the tool until just before you intend to make the fastening.
- Never place your hand or any other body part over the fastener loading end of the tool.
- Never carry the tool with your finger on the trigger.
- Never leave the tool unattended or allow anyone to operate it without first being trained.
- Never engage in horseplay with the tool.
- Always keep the tool pointed away from yourself or others.
- Never operate the tool if explosive or flammable materials are nearby.
- Keep the tool and supplies locked up and out of the reach of children.

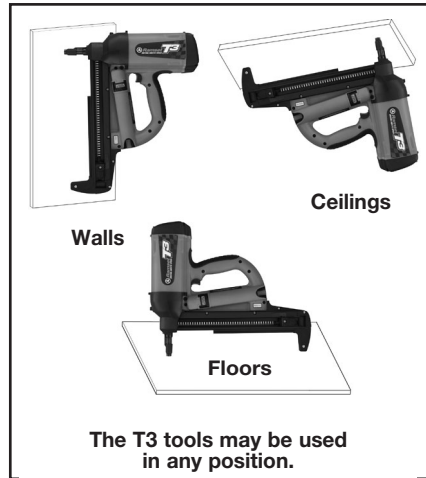

# BATTERY CELL AND CHARGING SYSTEM

---

## BATTERY CELL AND CHARGER

The first step in preparing a new tool for operation is to fully charge the new Battery. New Batteries are shipped discharged and must be charged for 24 hours before first use. All subsequent charges will require at most a 3 hour charge.



### Important Charging Notes



**CHEMICAL/  
EXPLOSION HAZARD**  
Read ALL instructions  
before charging or using  
battery. Failure to follow

ALL instructions may result in fire, severe burns, or release of toxic materials.

**Battery Disposal:** The EPA certified RBRC® Battery Recycling Seal on the nickel-cadmium (Ni-Cd) battery indicates Ramset is voluntarily participating in an industry program to collect and recycle these batteries at the end of their useful life, when taken out of service in the United States or Canada. The RBRC® program provides a convenient alternative to placing used Ni-Cd batteries into the trash or the municipal waste stream, which may be illegal in your area. Please call 1-800-8-BATTERY™ (1-800-822-8837) for information on Ni-Cd battery recycling and disposal in your area. Ramset's involvement in this program is part of our commitment to preserving our environment and conserving our natural resources.



Ramset  
Battery Charger

## CHARGING INSTRUCTIONS

1. Connect the round plug of the wall mount unit to the front of the charger base and plug the wall mount unit into any 120V AC outlet. A LED by the plug indicates the base unit has power.
2. Set the charger base on a stable surface and insert the battery or batteries, contact first, into the opening of the charger base.
3. The T3 charger incorporates a charge level indicator to inform the user of the battery charge level.

**A red light will illuminate at all times during a charge cycle.**

**One green light**

= battery at 50% capacity

**Two green lights**

= battery at 75% capacity

**Three green lights**

= battery at FULL capacity

**The red light will not be lit when the battery is at full charge.**

## CHARGING DONT'S

- Do not charge battery when temperature is below 40°F (5°C).
- Do not drop battery or charger.
- Do not allow metal objects to come in contact with battery terminals.
- Do not puncture or attempt to open battery case or cells.
- Do not store battery where it will be subjected to temperatures above 120°F (49°C).
- Do not incinerate battery.
- Do not use a defective battery charger, one that overheats and/or smokes when plugged in.

# BATTERY CELL AND CHARGING SYSTEM

---

### INSTALLING THE BATTERY

- Insert the battery into the tool as shown on the right with the clip facing to the side.
- The battery has two positions in the tool:
  1. The “OFF” position—as shown in picture #1 to the right.
  2. The “RUN” position—as shown in picture #2 to the right.
- To operate the tool be sure the battery is fully inserted into the tool. After installing the battery, note the LED light on the right side of the handle.
- If the light flashes green, the tool is powered.
- If the light flashes red, the battery requires charging.
- If the light is solid green and the fan is running, the tool is ready to take the next shot.
- If the light is solid red and the fan is not on, the battery needs to be recharged.
- If the tool will not be used for a short period of time, click the battery back into the “OFF” position. This will prevent the tool from being fired.
- If the tool will not be used for extended periods of time, remove the battery and store in the tool case.

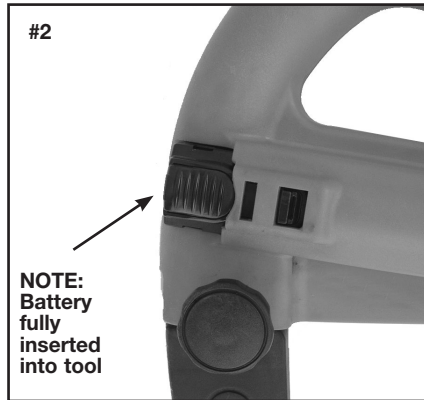
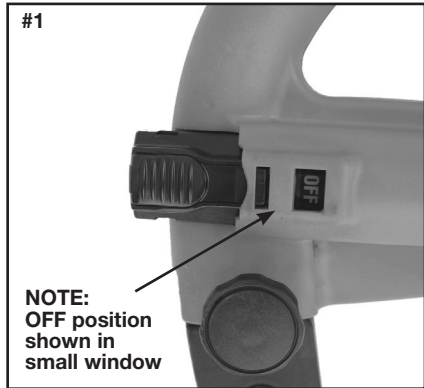

# FUEL CELL

---

## FUEL CELL

---



**DANGER**



### EXPLOSION/FIRE HAZARD

Read ALL safety instructions before using or handling the fuel cell. Failure to follow ALL instructions may result in explosion or fire. This may cause severe personal

injuries or property damage.

---



Keep the fuel cell away from heat, sparks and open flame.

---



Exposure to temperatures above 120°F (49°C) may cause the fuel cell to burst, releasing flammable gas.

---



**WARNING**



- Sunlight can raise the inside temperature of an unventilated car or van to above 140°F (60°C).
  - Do not puncture or attempt to open the fuel cell; it is non-refillable.
  - Do not incinerate, reclaim or recycle the fuel cell.
  - Do not smoke while installing or removing the fuel cell.
  - Do not inhale the spray.
  - Keep out of the reach of children.
  - Store fuel cell(s) in well-ventilated areas only.
  - Do not reuse fuel cell, adaptor or seal.
- 

The Ramset Fuel Cell contains liquid hydrocarbon fuel. This provides enough fuel to drive approximately 1,000 fasteners.

The Fuel Cell is designed for proper operation at temperatures between 15°F (-5°C) and 120°F (49°C)

There is a second container inside the fuel cell. The inner container holds the fuel. The space between the inner container and the outer cylinder is filled with a gas, called the propellant, which is under pressure.

To eject the fuel, propellant pressure squeezes the inner fuel container, much as you squeeze a tube of toothpaste. This squeezing action ensures that all the fuel is used, and that the T3 tools can operate in any position.

Because of this container-within-a-container design, you might hear the sound of fluid when shaking the fuel cell after all the fuel has been used. This is the propellant, which remains between the containers even after all the fuel has been expelled.

If you expose the empty fuel cell to extreme temperatures, the propellant gas will expand and could cause the container to burst, releasing flammable gases.

# FUEL CELL

---

### INSTALLING THE FUEL CELL

- The T3 fuel cell comes ready to use. There is no need for additional steps to prepare the fuel cell. The fuel cell also incorporates a usage indicator, to indicate a new fuel cell from a used fuel cell.
- There is a membrane over the top of the fuel cell adaptor. If the fuel cell has been used the membrane will have been pierced. See picture on the right
  1. Locate the port on the left rear of the tool and slide the fuel cell into position.
  2. Firmly push the fuel cell completely into the pocket until the adaptor on top of the fuel cell clicks into the tool.
  3. The fuel cell is now ready.
- To remove the fuel cell from the tool, push and release the “Fuel Eject” button located on the front left side of the tool.
- Excessive removal and installation of fuel cell will reduce the number of shots per cell.



Top of the Fuel Cell



#1



#2



#3

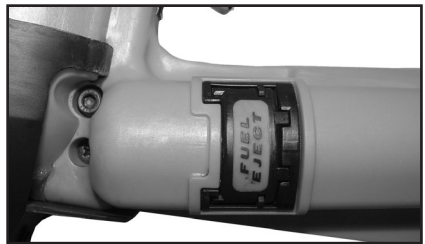

# T3SS TOOL OPERATING INSTRUCTIONS

## TOOL OPERATION

Always check the tool first to make sure that it does not contain a fastener. If the tool contains a fastener from a previous application, remove both the battery and the fuel cell before attempting to remove the fastener.

### Operating the T3SS Tool

1. Insert a charged battery into the tool with the battery contacts to the front.
2. Insert a good fuel cell into the tool as described on page 9.
3. With your finger off the trigger, insert the fastener you wish to use in the nose of the tool. Do not force the fastener into the tool such that you cause the work contact element to be pushed up into the tool body.
4. Note that the LED light on the side of the handle is a flashing green indicating the the tool is now ready to make a fastening.
5. Place the tool in the spot where you want to make your fastening.
6. With the tool in place and the supporting foot in contact with the work surface, hold the tool perpendicular compress the nose against the work surface and pull the trigger to make the fastening.
7. The tool is now ready for the next fastener.

To avoid overheating the tool, do not completely close off the air intake section on the top end of the tool.

### Removal of Rear Foot Assembly

1. Find the knob on the rear of the tool, turn the knob counter clockwise until it stops
2. Push the knob inward
3. Push the foot back, off of the handle assembly
4. Reverse the above procedure for installation

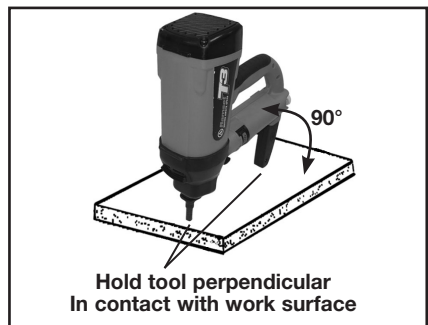
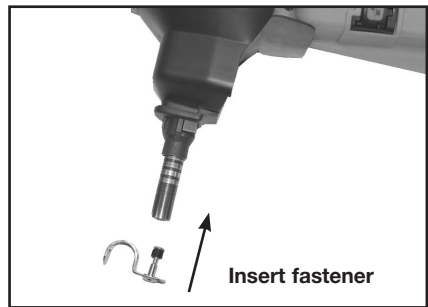
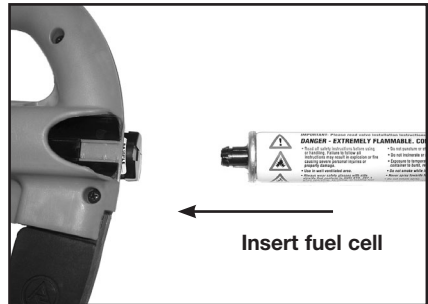
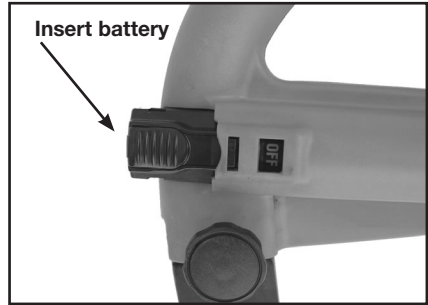

### QUICK CHANGE NOSE

The T3SS tool is equipped with a quick change nose. This feature allows the user to change the work contact element to meet various fastening needs. The work contact element can be changed without the use of tools by following these steps:

#### Removal

1. **Remove battery from the tool !!!**
2. **Firmly grasp the end of the Work Contact Element and turn it 90 degrees**
3. **Pull the Work Contact Element from the tool.**



#### Replace

1. **Orient the Work Contact Element so that the notched or flat portion is toward the back or the tool**
2. **Firmly push the Work Contact Element up into the nose piece.**
3. **Slightly twist the Work Contact Element to be sure it is fully engaged in the nose.**
4. **Insert the battery and operate the tool.**

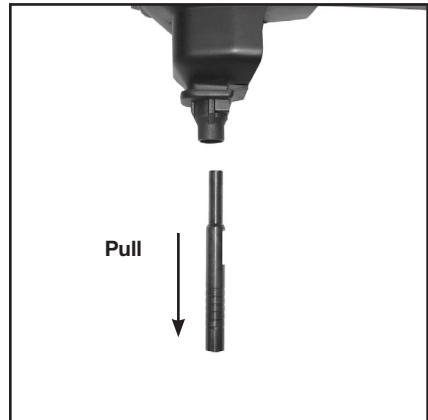

#### Work Contact Elements

P/N: M150200 – To be used with fasteners with pre-mounted 1/2" washers.

P/N: E150100 – To be used with straight pins, fasteners with eyelets, and fastener assemblies.



## SERVICING / TROUBLESHOOTING

SYMPTOM	POSSIBLE PROBLEMS	SERVICE
<b>Preparing Tool for Operation— Battery/Charger Problems</b>		
– Battery Cell does not appear to accept charge. Green charger light does not come on	– Inoperative indicator lights on charger	– Try Battery Cell in tool after 3 hours on charge cycle. If tool LED is green, charger lights are not working properly. Replace charger, or monitor charging time to ensure Battery Cell has adequate time for recharging. It's normal for Battery to feel warm after properly charging.
	– Battery Cell damaged or cycle life exhausted	– Replace Battery Cell
	– Damaged charger	– Discontinue use immediately and unplug from power source. Replace charger and tag or dispose of charger to prevent accidental reuse or connection to power source.
– Flashing lights on charger base unit	– Damaged Battery Cell – Battery Completely Drained	– Replace Battery – Allow battery to charge for 5 minutes
<b>Normal Stage of Operation</b>		
– Fan does not run – tool LED is off	– Battery in off position – Battery Cell is not charged – Battery terminals or battery contacts are oily, dirty, or corroded	– Fully insert Battery – Charge Battery Cell according to Operating Manual. – Clean Battery Cell terminals. Battery Cell contacts as required.
– Fan does not run, or runs slower than normal—tool LED is red	– Battery Cell is discharged	– Charge Battery Cell
– Fan does not run, tool LED flashes red/green	– Possible electronics error	– Remove, reinsert the Battery Contact Authorized Ramset Distributor Sales Representative for service.
<b>Pre-Combustion/Combustion Stage of Operation</b>		
– Work Contacting Element does not depress fully—tool does not operate	– Work Contacting Element is bent, or build-up of debris in nose restricts operation – O-Ring pinched	– Remove and inspect Work Contact Element. Repair or replace Work Contact Element as required. – Contact Authorized Ramset Distributor Sales Representative for service.
<b>(For T3 Magazine tool only)</b>	– Tool is out of fasteners	– Add fastener strip
– Tool will not cycle—fan runs, LED is green	– Fuel Cell is empty – Spark does not occur.	– Replace Fuel Cell – Contact Authorized Ramset Distributor Sales Representative for service.

## SERVICING / TROUBLESHOOTING

SYMPTOM	POSSIBLE PROBLEMS	SERVICE
<b>Power/Exhaust Stage of Operation</b>		
– Tool operates properly, but fasteners do not drive fully	– Battery cell is discharged	– Charge Battery Cell
	– Fuel Cell is low	– Check Fuel Cell according to Operating Manual and replace as required.
	– There may be loss of seal in combustion chamber	– Press Work Contact Element against workpiece for one minute. Pull trigger. If fastener does not drive, there is a leak that requires service.
– Tool operates erratically or appears to be losing power— tool LED is green	– Fuel Cell is low	– Check Fuel Cell according to Operating Manual
	– Filter element is dirty, causing tool to overheat	– Remove Filter element and clean according to Operating Manual. Use safe cleaning solution to remove stubborn debris.
	– Tool Sleeve or O-Rings are dirty	– Clean tool per Cleaning Procedure
<b>Returning/Purging Stage of Operation</b>		
– Tool operated and drove fastener, but piston did not return to start position	– Built-up dirt and debris on Piston or in Nose bore	– Clean Piston and Nose bore with safety solvent. See Cleaning Procedure.
	– Mushrooming of Piston Tip	– Contact Ramset Distributor Sales Representative for service.
	– Exhaust ports on the Sleeve are dirty or clogged.	– Return tool to Authorized Ramset Distributor Sales Representative for service.
	– Tool (Sleeve) or O-Rings are dirty	– Clean tool per Cleaning Procedure
– Tool does not open after tool fires	– Work Contacting Element is bent, or tool is dirty	– Clean tool or replace Work Contacting Element as required.

**If the T3SS or T3 Magazine tool will not operate after following the above service directions, return the tool to an Ramset Distributor Sales Representative for service.**

**RAMSET GAS TOOL SYSTEMS WARRANTY AND LIMITATIONS**

Ramset warrants that new T3SS and T3 Magazine systems power fastening tools, parts and accessories will be free from defects in material and workmanship for the period shown below.

**TWO-YEAR/50,000 SHOT WARRANTY**

A two-year/50,000 shot warranty, which ever comes first, will apply to all parts, except those listed below as normal wearing parts, or parts which are specifically covered by an extended warranty.

**SIX-MONTH/10,000 SHOT WARRANTY**

A six-month/10,000 shot warranty applies to the following parts, which are considered normal wearing parts:

- Bumper
- Piston Assembly
- O-Rings
- Piston Rings

The warranty period is based off of tool build date, determined from the tool serial number. Ramset may extend the warranty time frame from the date of purchase with a qualifying document proving date of purchase.

**WARRANTY STATEMENT**

Ramset's sole liability hereunder will be to replace any part or accessory which proves to be defective within the specific time period. Any replacement part or accessory provided in accordance with this warranty will carry a warranty for the balance of the period of warranty applicable to the part it replaces. This warranty does not apply to part replacement required due to normal wear.

This warranty is void as to any tool which has been subjected to misuse, abuse, accidental or intentional damage, use with fasteners, fuel, battery, or battery chargers not meeting Ramset specification, size, or quality, improperly maintained, repaired with other than genuine T3 replacement parts, damaged in transit or handling, or which, in Ramset's opinion, has been altered or repaired in a way that affects or detracts from the performance of the tool.

Ramset **MAKES NO WARRANTY, EXPRESSED OR IMPLIED, RELATING TO MERCHANTABILITY, FITNESS, OR OTHERWISE, EXCEPT AS STATED ABOVE** and the liability **AS STATED ABOVE AND AS ASSUMED ABOVE** is in lieu of all other warranties arising out of, or in connection with, the use and performance of the tool, except to the extent otherwise provided by applicable law.

Ramset **SHALL IN NO EVENT BE LIABLE FOR ANY DIRECT, INDIRECT, OR CONSEQUENTIAL DAMAGES, INCLUDING, BUT NOT LIMITED TO DAMAGES WHICH MAY ARISE FROM LOSS OF ANTICIPATED PROFITS OR PRODUCTION, SPOILAGE OF MATERIALS, INCREASED COST OF OPERATION OR OTHERWISE.**

Ramset reserves the right to change specifications, equipment, or designs at any time without notice and without incurring obligation.

**FOR TOOL REPAIR SERVICE CONTACT YOUR LOCAL  
AUTHORIZED RAMSET DISTRIBUTOR OR TO FIND  
YOUR NEAREST RAMSET TOOL REPAIR CENTER  
VISIT OUR WEB SITE AT [WWW.RAMSET.COM](http://WWW.RAMSET.COM)  
OR CALL 800-241-5640 (CANADA 1-800-387-9692)**



**Concrete Fastening Systems  
Glendale Heights, IL 60139  
800-RAMSET6 (1-800-726-7386)  
(Canada 1-800-387-9692)  
[www.ramset.com](http://www.ramset.com)**

**Buy with Confidence...  
Buy From Your Authorized Distributor**

**AN ILLINOIS TOOL WORKS COMPANY  
© ILLINOIS TOOL WORKS 2011**