



DANGER



READ AND OBEY ALL SAFETY AND OPERATING
INSTRUCTIONS BEFORE OPERATING TOOL.



Ramset[®]
FASTENING SYSTEMS

RAMSET R150 TOOL

OPERATOR'S SAFETY & OPERATING INSTRUCTION MANUAL



**GAS POWERED, LOW VELOCITY
PISTON TYPE FASTENING TOOL**

//TW Ramset/Red Head[®]



DANGER



THIS TOOL IS TO BE USED ONLY BY PROPERLY TRAINED OPERATORS. ATTEMPTING TO HANDLE OR OPERATE THE R150 GAS POWERED TOOL WITHOUT PROPER TRAINING CAN RESULT IN SERIOUS INJURY TO THE OPERATOR OR BYSTANDERS.



! Read, understand and follow the instructions in the tool manual before attempting to use the tool.



! Operators and Bystanders must wear eye and hearing protection.



! Never close tool with hand over the fastener loading end of the tool. A serious hand injury from penetration by the piston or fastener could result.



! The gas in fuel cells is under pressure and the gas is flammable.

! Do not open, puncture or burn fuel cells.



! Store fuel cells in a well ventilated area, at temperatures below 50° C (122° F) and out of the sunlight.

! Keep fuel cells away from flames, sparks and heat.

! Do not attempt to recharge, refill or recycle fuel cells.

! Never operate the R150 tool if flammable or explosive materials are nearby.



DANGER



Just as no one can merely read a book about driving an automobile and then hope to drive one safely, no one should attempt to use the R150 gas powered tool without adequate, competent personal instruction.

No automobile instruction book or instructor can forewarn a learner against all possibilities and emergencies, nor can printed material detail all possible conditions surrounding the use of ITW Ramset/Red Head tools and products.

Responsibility for the safe and proper use of this tool rests with the tool user and the employer.

Preparation For Fastening

Acceptable Base Materials

The gas powered R150 tool is suitable for use in the following base materials only:

- Poured Concrete
- Structural Steel
- Concrete Block and Horizontal Joints in Brick or Masonry Walls

Never attempt to fasten into any other type of material. *Fastening into other materials can cause blindness or other serious injury.*

Never attempt to fasten into very hard or brittle materials such as cast iron, tile, glass, or rock of any type. *These materials can shatter, causing the fastener and/or base material fragments to fly free and cause serious injury to the tool operator and others.*

Never fasten into any base material that does not pass the Center Punch test. *Failure to assure the suitability of the base material can result in serious injury to the eyes or other body parts.*

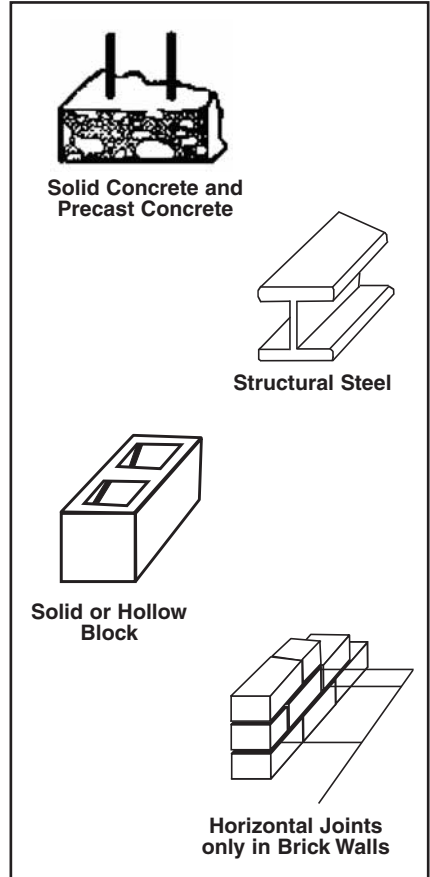

Center Punch Test

ALWAYS WEAR SAFETY GOGGLES WHEN PERFORMING THIS TEST.

1. Always check the material being fastened into for hardness before attempting any fastening operation.
2. Using a fastener as a center punch, strike the fastener against the work surface using an average hammer blow and check the results.

Center Punch Test Results

1. If the fastener point is flattened, the material is too hard for a powder actuated fastening.
2. If the fastener penetrates the material easily, the material is too soft.
3. If the material cracks or shatters, the material is too brittle.
4. If the fastener makes a small indentation into the material, the material is suitable for fastening.

Fuel Cells and Batteries

Fuel Cells

- The fuel cell must be used at temperatures between -5°C (23°F) and 49°C (120°F).
- At the beginning of each fastening cycle, a measured amount of gas is injected into the combustion chamber.
- The fuel cell is designed with an internal reservoir that is under pressure by a propellant.
- When the fuel cell is empty, a small amount of propellant remains inside the cell.
- For safety and proper tool functioning it is important that only Ramset supplied fuel cells be used in the R150 tool.

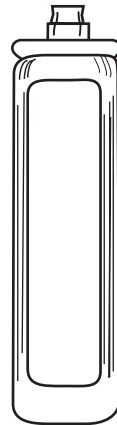

Ramset Fuel Cell

Batteries

- The battery will become discharged even if the tool is not being used.
- Remove the battery from the tool when the tool is not to be used or put it in the “no contact” position in the tool as shown on page 5.
- Recharge the battery if it has not been used for a long period of time.
- Batteries are supplied in an uncharged condition so fully charge them for first time use.
- Do not recharge batteries until they are fully discharged.
- It takes about 1 hour to recharge a battery.
- Use only batteries and chargers supplied by Ramset.
- Battery Capacity—Maximum 1200 shots.

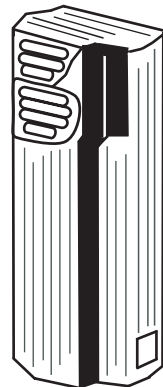

Ramset 6 V. Battery

Installing the battery

- Insert the battery into the tool as shown on the right with the clip toward the rear.
- Note the LED light on the right side of the handle. After installing the battery:
 - If the light flashes green the tool is powered.
 - If the light flashes red the battery requires charging.
 - If the light is solid green and the fan is running, the tool is ready to use.
 - If the light is solid red and the fan is not on the battery needs recharged.

Battery is shown in the “no contact” position. Push it fully down to lock it in place.

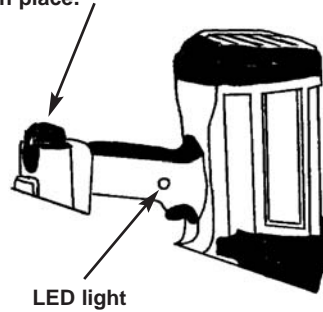

Installing the fuel cell

- There is a cap located on the rear of the tool handle that covers the fuel cell. Twist the cap 1/8 turn clockwise and remove it.
- Insert the fuel cell, nose first, all the way into the recess.
- Replace the cap by lining up the lugs on the cap with the notches in the tool handle, push the cap in and twist it 1/8 turn counterclockwise to the locked position.

Turn and remove housing cap

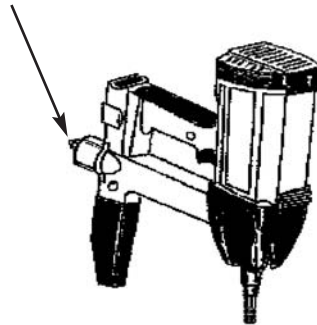

Insert fuel cell into recess

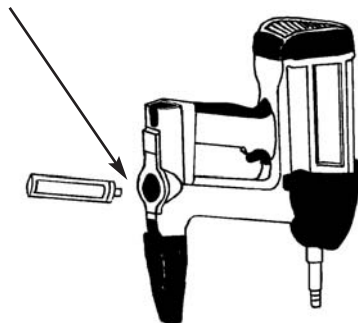

FAILURE TO FOLLOW INSTRUCTIONS CAN CAUSE INJURY TO THE TOOL OPERATOR OR TO BYSTANDERS.

- Use the tool only in well ventilated areas.
- Always hold the tool at right angles to the work surface.
- Never attempt to make a fastening at an angle to the work surface.
- While the tool can be used in any position (floor, wall or ceiling) it is important to have both the nose of the tool and support foot in contact with the work surface to minimize spall and make the best quality fastenings.
- Do not put a fastener into the nose of the tool until just before you intend to make the fastening.
- Never put your hand over the nose end of the tool.
- Never put your hand on or over the end of the tool to close the tool.
- Never carry the tool with your finger on the trigger.
- Never leave the tool unattended or allow anyone to operate it without first being trained.
- Never engage in horseplay with the tool.
- Always keep the tool pointed away from yourself or others.
- Never operate the tool if explosive or flammable materials are nearby.
- Keep the tool and supplies locked up and out of the reach of children.

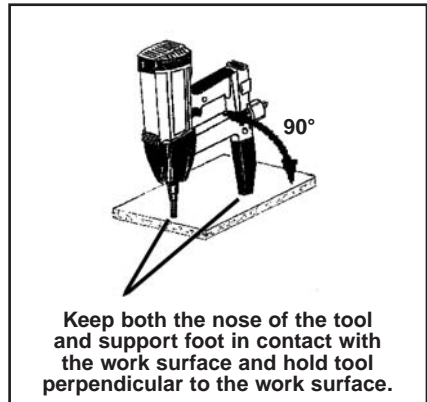
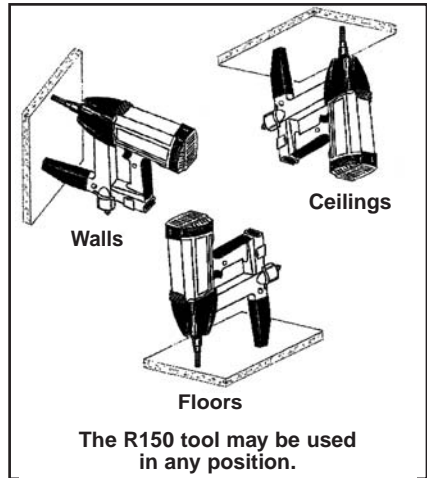

FASTENING APPLICATIONS

FASTENING APPLICATIONS

Your R150 tool can be used for a wide range of fastening needs in a variety of base materials. Reading and following these important fastening guidelines will help you get the best results from your tool and fasteners, as well as help you perform these fastening operations safely and effectively.

R150 fastenings are permanent fastenings so attempting to remove a fastener from concrete or steel may result in a serious injury.

Fastening to Concrete

When fastening into concrete, always maintain a minimum spacing of 3" between fastenings and 3" from any free edge. Concrete thickness should be at least three times the intended penetration depth into the concrete.

Driving fasteners too close to an edge or too close to each other can cause the concrete edge to fail or fasteners to fly free.

Fastening to Concrete Block or to Masonry Walls

Take care to observe a 3" edge distance to avoid cracking the block and over penetration of the fastener to avoid a loss of holding value. Fastenings may also be made into the horizontal joint but not into the vertical joint.

Fastening to Steel

Your R150 tool can be used for fastening on the flat surfaces of structural steel. When fastening into steel, always maintain a minimum spacing of 1-1/2" between fastenings and 1/2" from any edge.

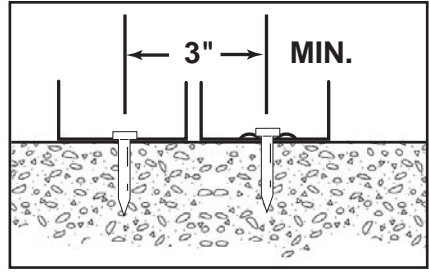

PENETRATION - THIN GAUGE METAL TO CONCRETE

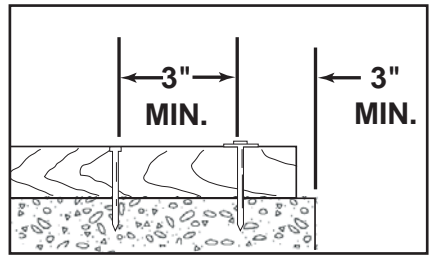

SPACING - THIN WOOD STRIP TO CONCRETE

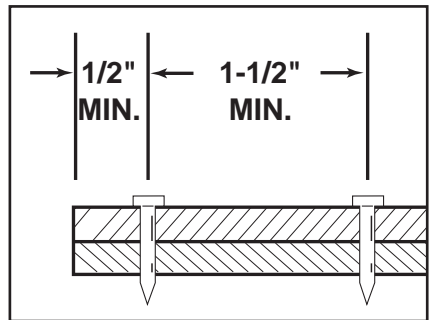

SPACING STEEL TO STEEL

TOOL OPERATING INSTRUCTIONS

TOOL OPERATION

Always check the tool first to make sure that it does not contain a fastener. If the tool contains a fastener from a previous application, remove both the battery and the fuel cell before attempting to remove the fastener.

Operating the R150 Tool

1. Insert a charged battery into the tool with the battery contacts to the front.
2. Insert a good fuel cell into the tool as described on page 5.
3. With your finger off the trigger, insert the fastener you wish to use in the muzzle bushing of the tool. Do not force the fastener into the tool such that you cause the muzzle bushing to be pushed up into the tool body.
4. Note that the LED light on the side of the handle is a solid green indicating the tool is now ready to make a fastening.
5. Place the tool in the spot where you want to make your fastening.
6. With the tool in place and the supporting foot in contact with the work surface, hold the tool perpendicular and pull the trigger to make the fastening.
7. The tool is now ready for the next fastener.

To avoid overheating the tool do not hold your hand over the air intake section on the top end of the tool.

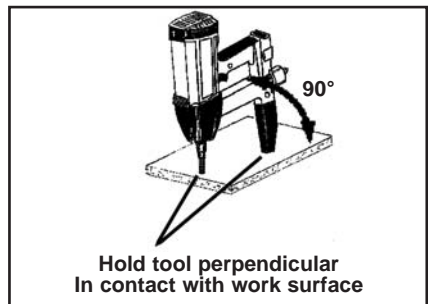
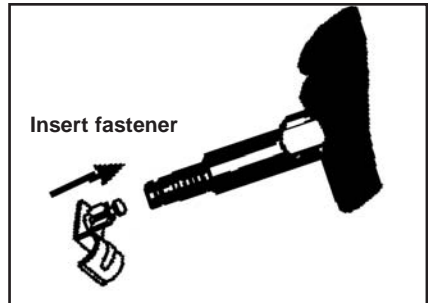
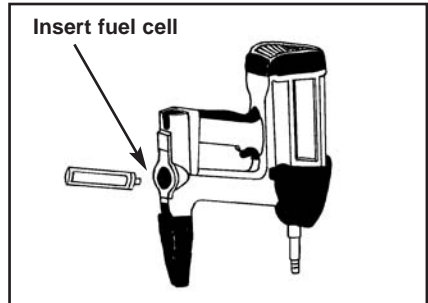
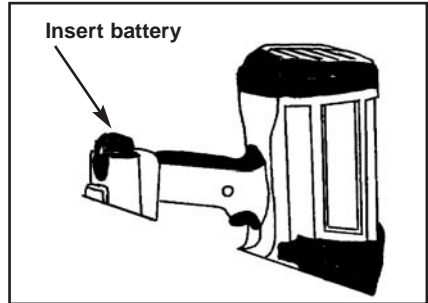

QUICK CHANGE NOSE

The R150 tool is equipped with a quick change nose. This feature allows the user to change the work contact element to meet various fastening needs. The work contact element can be changed without the use of tools by following these steps:

Removal

1. **Remove battery from the tool !!!**
2. Firmly grasp the end of the Work Contact Element and turn it 90 degrees
3. Pull the Work Contact Element from the tool.

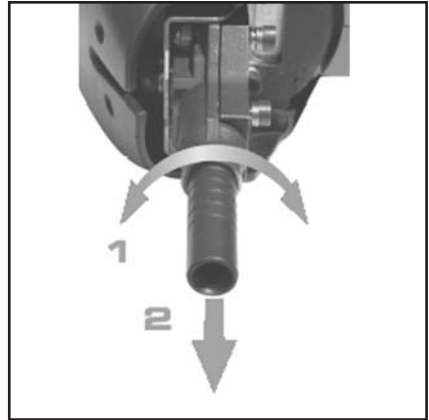

Replace

1. Orient the Work Contact Element so that the notched or flat portion is toward the back or the tool
2. Firmly push the Work Contact Element up into the nose piece.
3. Slightly twist the Work Contact Element to be sure it is fully engaged in the nose.
NOTE: There should be no open gap between the shear block plate and the nose piece.
4. Insert the battery and operate the tool.

Work Contact Elements

P/N: M150200 – To be used with fasteners with pre-mounted 1/2" washers.

P/N: E150100 – To be used with straight pins, fasteners with eyelets, and fastener assemblies.

PARTS SCHEMATIC

R150 TOOL SCHEMATIC

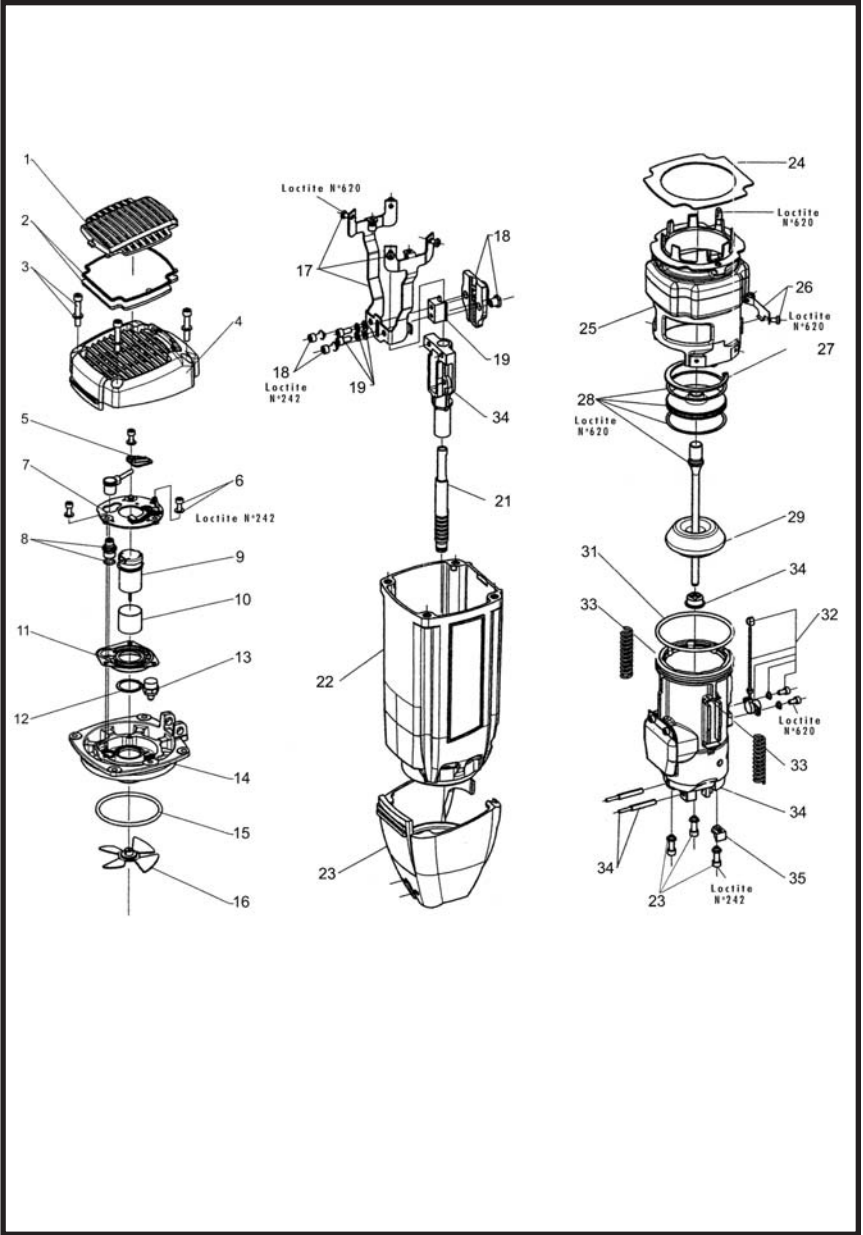

PARTS SCHEMATIC

R150 TOOL SCHEMATIC (continued)

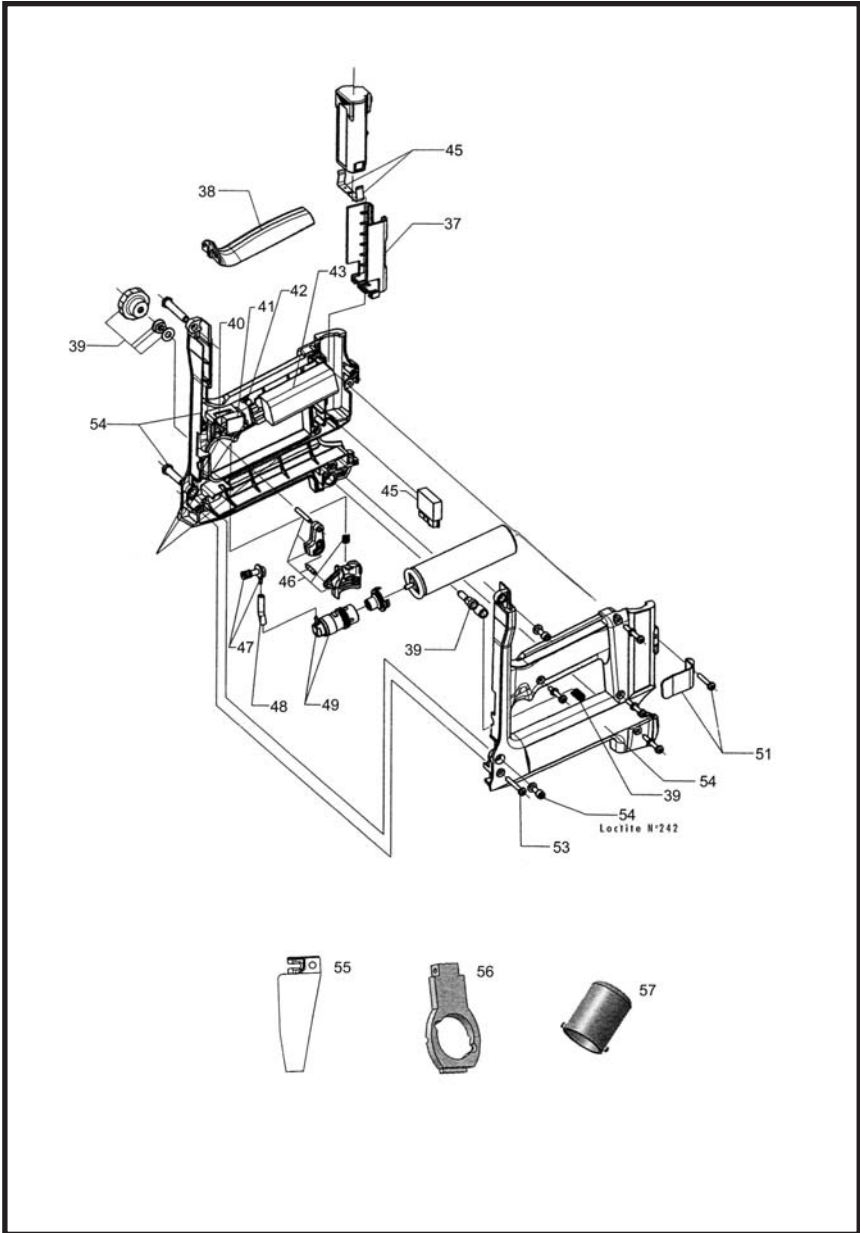

PARTS LISTS

RAMSET R150 TOOL PARTS LISTS

KEY	PART NUMBER	DESCRIPTION
1	336920	GRILL CAP
2	336900	AIR FILTER
3	B0060A	CAP SCREWS M5-30 W/WASHER (pkg of 4)
4	339000	CAP ASSEMBLY
5	B0070	SPARK PLUG WIRE
6	B0061A	PC BOARD SCREWS, M4-12 (pkg of 3)
7	B0040	PC BOARD
8	7505164	SPARK PLUG ASSEMBLY
9	900525A	FAN MOTOR ASSEMBLY (INCLUDES FAN, MOTOR SLEEVE, MOTOR MOUNT, RETAINING RING AND FAN BLADE)
10	401356	MOTOR SLEEVE
11	900470	MOTOR MOUNT
12	401355	MOTOR RETAINING RING
13	404601	HEAD SWITCH
14	B0078	CYLINDER HEAD
15	403992	O-RING, CYLINDER HEAD
16	403167	FAN BLADE
17	B0044	CAGE ASSEMBLY
18	EM150300A	SHEAR BLOCK PLATE KIT (INCLUDES: PLATE AND TWO M5 SCREWS)
19	333180	TIE BAR ASSEMBLY - W/SCREWS
21	M150200	WORK CONTACT ELEMENT (Mechanical)
	E150100	WORK CONTACT ELEMENT (Electrical)
22	339030	HOUSING BODY ASSEMBLY
23	333220	RUBBER DEFECTOR ASSEMBLY
24	B0038	AIR DAM
25	B0082	COMBUSTION CHAMBER
26	333250	COMBUSTION CHAMBER STOP ASSEMBLY
27	B0068	PISTON STOP RETAINING RING
28	333270	PISTON ASSEMBLY
28A	B0034A	PISTON RINGS (pkg of 2)
29	B0053	BUMPER
31	B0042	SLEEVE O-RING

RAMSET R150 TOOL PARTS LISTS *(continued)*

KEY	PART NUMBER	DESCRIPTION
32	339050	GAS DUCT ASSEMBLY
33	B0037A	CHAMBER SPRINGS (pkg of 2)
34	339060M	SLEEVE/NOSE ASSEMBLY
35	B0105	SECURITY STOP
37	334020	BATTERY SUPPORT
38	337440	RUBBER HANDLE, GRIP
39	333380	KNOB ASSEMBLY
40	404619	INSULATOR
41	404490	TRIGGER SWITCH ASSEMBLY
42	404385	LIGHT CONDUIT
43	B0098	SPARK UNIT ASSEMBLY, MEFI
45	010422	EFI JUNCTION BOARD
46	333450	TRIGGER ASSEMBLY
47	333460A	FEED ASSEMBLY (INCLUDES: FUEL FEED ASSEMBLY & FEED TUBE)
49	333480A	FUEL INJECTION ASSEMBLY (INCLUDES: FUEL FEED ASSEMBLY & FUEL FEED TUBE)
51	336870	BELT HOOK
53	B0062A	HANDLE SCREWS (pkg of 5)
54	010900	LEFT/RIGHT SIDE HANDLE ASSEMBLY
55	B0144	REAR FOOT ASSEMBLY
56	EM150330	FUEL CELL CUP BRACKET
57	EM150340A	FUEL CELL RETAINING CUP ASSEMBLY
*	334000	BATTERY
*	7505142	BATTERY CHARGER W/WALL MOUNT ADAPTOR

SERVICING/TROUBLESHOOTING

**FOR SERVICING REQUIRED BUT NOT LISTED IN THIS MANUAL,
PLEASE CONTACT YOUR LOCAL DISTRIBUTOR**

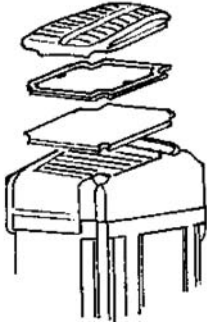

Filters and Battery Contacts

Cleaning the filters and battery contacts on a regular basis will help make your tool work more efficiently.

To clean the filters

- Remove the cover and the filters.
- Lightly tap the filters to remove any dust.
- Replace the filters if damaged.
- Replace the filters and the cover.

To clean the battery contacts

- Periodically wipe contacts with a dry, soft cloth.
- Should they show corrosion, clean with a piece of very fine emery cloth and clean with a dry cloth.

TROUBLESHOOTING

Tool does not work

- | | | |
|--------------------|---------------------------------|-------------------|
| - LED light is off | - No battery in tool | - Install battery |
| - LED flashes red | - Battery completely discharged | - Charge battery |
-

Fan is on but the tool does not fire

- | | | |
|----------------|----------------------------|------------------------|
| - LED is red | - Battery power is too low | - Recharge battery |
| - LED is green | - Fuel cell is exhausted | - Put in new fuel cell |
-

Fan stops after the trigger is pulled and LED is green

- Call your local distributor for service
-

Tool firing is not consistent and LED is green

- Fuel cell is exhausted
 - Put in a new fuel cell
-

Fasteners are not completely set

- | | |
|-----------------------------|--------------------------|
| - Fuel cell is exhausted | - Put in a new fuel cell |
| - Filters are too dirty | - Clean/replace filters |
| - Base material is too hard | - Consult distributor |
-

Tool makes low sound

- | | |
|---------------------|----------------------------------|
| - piston stays down | - Consult your local distributor |
| - no fastening made | |
| - LED is green | |
-

Tool is sluggish and overheats

- | | |
|-------------------------|-------------------------|
| - Filters are too dirty | - Clean/replace filters |
|-------------------------|-------------------------|
-

SERVICING/TROUBLESHOOTING

R150 TOOL WARRANTY AND LIMITATIONS

ITW Ramset/Red Head warranty that new R150 power fastening tools, parts and accessories will be free from defects in material and workmanship for the period shown below, after the date of delivery to the original user.

TWO-YEAR WARRANTY

A two-year warranty will apply to all parts, except those listed below as normal wearing parts, or parts which are specifically covered by an extended warranty.

SIX-MONTH WARRANTY

A six-month warranty applies to the following parts, which are considered normal wearing parts:

- Bumper
- Piston Assembly
- O-Rings
- Piston Rings

WARRANTY STATEMENT

ITW Ramset/Red Head's sole liability hereunder will be to replace any part or accessory which proves to be defective within the specific time period. Any replacement part or accessory provided in accordance with this warranty will carry a warranty for the balance of the period of warranty applicable to the part it replaces. This warranty does not apply to part replacement required due to normal wear.

This warranty is void as to any tool which has been subjected to misuse, abuse, accidental or intentional damage, use with fasteners, fuel, battery, or battery chargers not meeting ITW Ramset/Red Head specification, size, or quality, improperly maintained, repaired with other than genuine R150 replacement parts, damaged in transit or handling, or which, in ITW Ramset/Red Head's opinion, has been altered or repaired in a way that affects or detracts from the performance of the tool.

ITW RAMSET/ RED HEAD MAKES NO WARRANTY, EXPRESSED OR IMPLIED, RELATING TO MERCHANTABILITY, FITNESS, OR OTHERWISE, EXCEPT AS STATED ABOVE and the liability AS STATED ABOVE AND AS ASSUMED ABOVE is in lieu of all other warranties arising out of, or in connection with, the use and performance of the tool, except to the extent otherwise provided by applicable law.

ITW RAMSET/RED HEAD SHALL IN NO EVENT BE LIABLE FOR ANY DIRECT, INDIRECT, OR CONSEQUENTIAL DAMAGES, INCLUDING, BUT NOT LIMITED TO DAMAGES WHICH MAY ARISE FROM LOSS OF ANTICIPATED PROFITS OR PRODUCTION, SPOILAGE OF MATERIALS, INCREASED COST OF OPERATION OR OTHERWISE.

ITW Ramset/Red Head reserves the right to change specifications, equipment, or designs at any time without notice and without incurring obligation.

**FOR TOOL REPAIR SERVICE CONTACT YOUR LOCAL
AUTHORIZED ITW RAMSET/RED HEAD DISTRIBUTOR OR CONTACT
YOUR NEAREST RAMSET TOOL REPAIR CENTER**

WEST

Los Angeles, CA

5950 Boxford
Commerce, CA 90040
Phone: 800-368-9724 (CA only)
Phone: 800-227-1823
Fax: 800-253-6444

MIDWEST

Paris, KY

7000 Bypass Road
Paris, KY 40361
Phone: 800-816-6645
Fax: 800-816-6673

EAST

Allentown, PA

739 Roble Road
Allentown, PA 18109
Phone: 800-266-9723
Fax: 610-266-0962



**Concrete Fastening Systems
Wood Dale, IL 60191
630-350-0370
www.ramset-redhead.com**

**Buy with Confidence...
Buy From Your Authorized Distributor**

© ILLINOIS TOOL WORKS 2005